



# YOUR SAFETY IS OUR PRIORITY

**ABROL  
ENTERPRISES**



+91 9915222897



[www.abrolventures.com](http://www.abrolventures.com)



[sale@abrolventures.com](mailto:sale@abrolventures.com)

# Table Of Contents

- ▶ About Us
- ▶ Our Services
  - Fire Hydrant System
  - Fire Suppression System
  - Fire Alarm System
  - Fire Extinguisher
  - Fire Rated Doors
  - Surveillance System
  - Smart Lighting System
  - Automatic Gates + Turnstiles
  - Access Control System
  - Home Security System
  - Metal Detector
  - PA & EPBAX
- ▶ Our Clients and Recognitions

# About Us



Our mission is to provide you highest quality products and services. To be the leading provider of security products, services and solutions in India and establishing ourselves as a premier brand in the India market by continuous commitment towards excellence in quality, high performance, dedicated teamwork and customer satisfaction, allowing us to achieve sustainable and profitable growth.

We will become a trusted brand in the global industry, nurturing in our customers and communities an eternal sense of loyalty towards our products and services.

- Unique and creative solutions that meet the clients' expectations not only by realizing the clients' business objectives, but particularly by our strict adherence to the ethical principles of public relations.
- Continuous search for opportunities beyond the agreed communications and business objectives.
- Creative approaches to the clients' special needs in order to find unique and tailored communications solutions.
- Team work based on the implementation of progressive communications disciplines.
- Professional quality of services provided by a highly motivated team.
- Courage and readiness to communicate on behalf of client in crisis.
- Strong technological background.
- Honesty & Complete Work fulfill availability.

**Onsite support Team** – On specific request, we provide short term as well as long-term onsite support to some of our large clients. These teams are composed of people well versed with the application as well as the client's requirements. They are supplemented by the experts in our development/implementation and support teams.

We would therefore request you to kindly register our name in your esteemed organization and favor us with your valued enquiries to enable us to submit our competitive offers for your kind Consideration.

We are now awaiting your esteemed enquiries and confirmed Orders which will receive our best and prompt action and services always.

We lay special emphasis on the quality aspect of our products and have never compromised on the same. We have highly experience and qualified technical team and in case of trouble shooting complete technical support will be provided to you at our end.

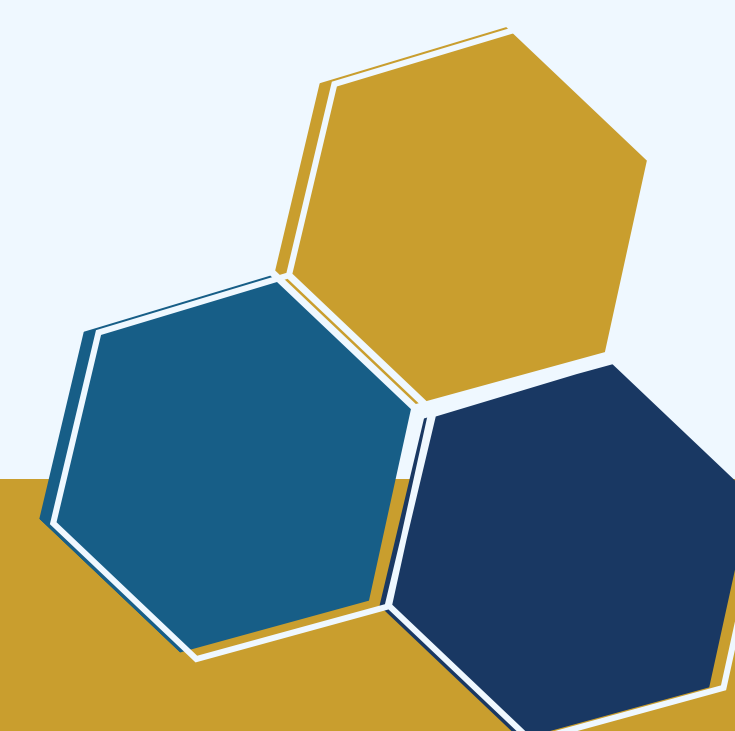
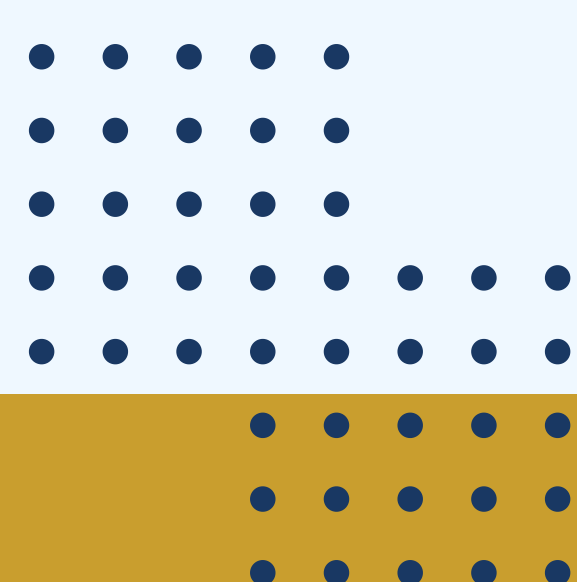

# FIRE HYDRANT SYSTEM

We offer a wide array of premium quality automatic fire hydrant & sprinkler systems. These systems are precision engineered and fabricated using high grade material to ensure durability and quality



## FIRE HYDRANT & SPRINKLER SYSTEM PRODUCT COMPONENTS:

### Hydrant Valve:

- a. Single Headed Hydrant Valve 63 mm dia. With ISI mark.
- b. Double Headed Hydrant Valve 63 mm dia. With ISI mark

**Hose Reel Drum with Hose and Nozzle:** Fire Hose Reel Drums are wall mounted type and can suit 30mtr of 19mm dia. rubber hose with nozzle and have a rolling capacity of 30 mtrs. Fabricated using natural or synthetic rubber, highly dependable and durable.

### Fire Fighting Hose:

- a. Percolating fire fighting hose having inside special rubber coating in 15 Meters length with Stainless Steel Male & Female Couplings binded with copper wire.
- b. 63 mm internal Dia. brand non percolating Fire Fighting hose bearing ISI mark quality systems in length of 15 meters.

### Branch Pipe:

Branch Pipe Gun Metal 63 mm dia. male instantaneous inlet and male threaded outlet complete with hexagonal base bore Nozzles with ISI Mark.

### Hose Box:

MS Hose Box Double Door Size: 24" x 30" x 10" are fabricated from high quality made from thick plate mild steel with glass door fram per ISI Specification.

### Fire Brigade Inlet:

- a. Two way Fire Brigade inlet
- b. Three way Fire Brigade inlet
- c. Four way Fire brigade inlet

**Gun Metal Coupling:** Gun Metal Male & Female Coupling 63mm Dia with ISI mark.

**Upright and Pendent Sprinkler:** The Upright and Pendent Sprinklers are automatic sprinklers of the frangible bulb type. They are intended for use in fire sprinkler systems designed in accordance with the standard installation rules recognized by the applicable Listing or Approval agency. The Upright, Pendent Sprinklers all produce a hemispherical water distribution pattern below the deflector.

**Yard Hydrant:** Yard Hydrant with Single Headed Hydrant Valve 63 mm dia with ISI mark



# TOTAL FLOODING SYSTEM

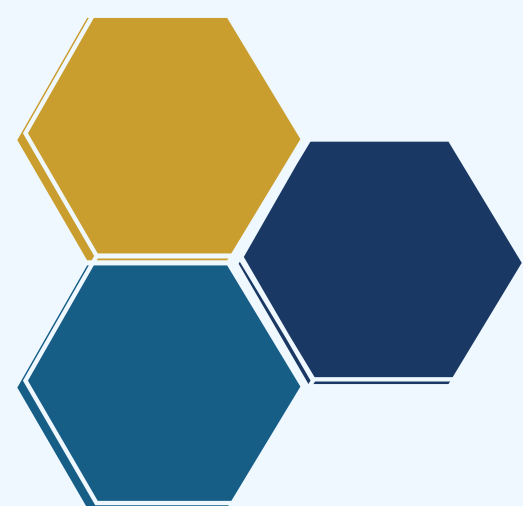

ABR total flooding system is a fixed suppression system which is arranged to automatically discharge a predetermined concentration of agent into an enclosed space for the purpose of fire extinguishment or control. Each system is custom engineered to quickly suppress fires while eliminating agent cleanup and minimizing the downtime that can be associated with other agent types.



Data centres

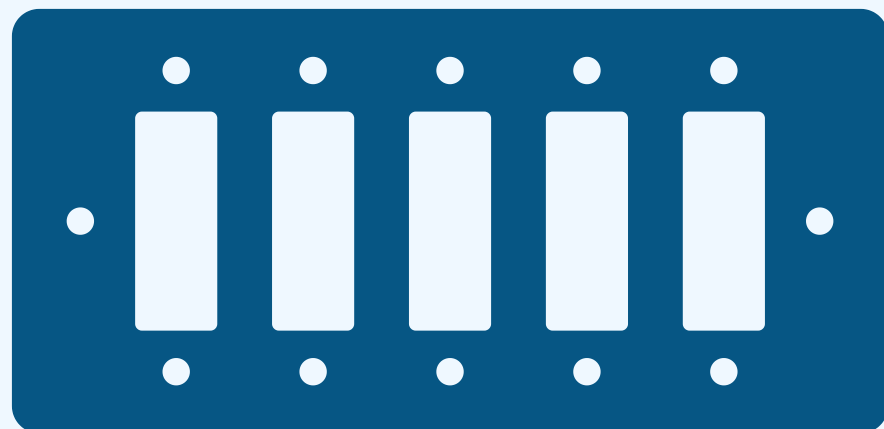

Electrical Switching Rooms



Heritage Sites

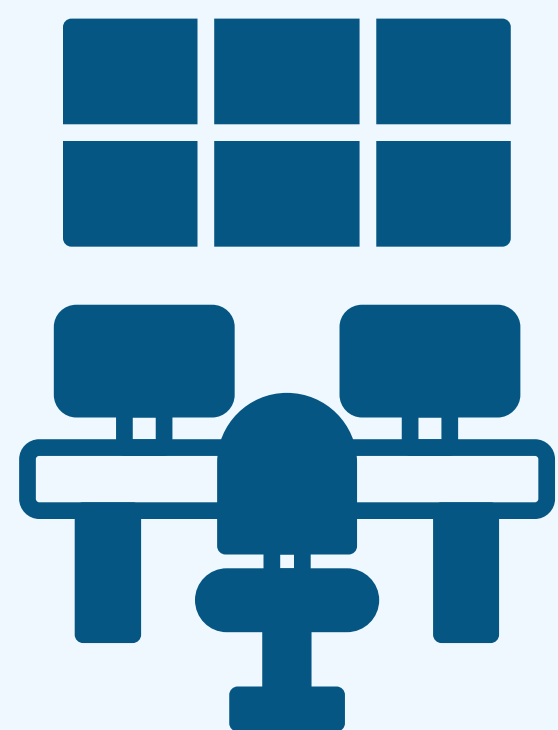

Electrical control rooms

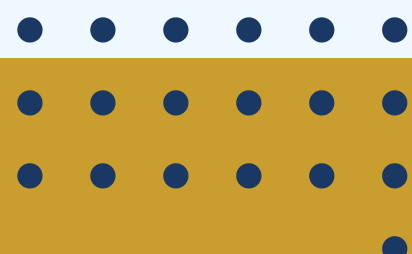

## FEATURES

- Safe for electrical/electronic equipment.
- Environmental Friendliness
- 24X7 protection with design Flexibility
- Zero or minimum Downtime/Cleanup
- Wide acceptance

## ABR SERVICES:

- Analysis of fire hazard
- System design and support
- Installation and service

## WHAT ARE THE VARIOUS TYPES OF FIRE SUPPRESSION SYSTEMS AVAILABLE TODAY?

Chemical Clean Agent gases Include 3M Novec-1230 (FK 5112), FM-200 (HFC-227ea), Fire Protection Fluid and others, all of which offer fast-acting, and most importantly, people-safe fire-suppressing solutions.

In the current scenario/field of fire suppression, Novec-1230 (Generic name: FK 5112) gas is the most recent generation of gas-based chemical extinguishing systems, with a variety of distinctive features and benefits. Novec-1230 is based on a long-term, sustainable technology with one of the highest safety margins and offers swift and reliable extinguishment with minimal environmental impact, particularly on global warming.

It works by completely flooding the area, and extinguishing the flames in a matter of seconds. It is appropriate for the dangers of classes A, B, and C. ABR extinguishing system is completely tailored to the unique features of the agent, resulting in the most dependable and cost-effective solutions.

Inert Gases - Include nitrogen, argon and CO<sub>2</sub>, or a combination of two or more, and reduce oxygen levels to a point where combustion cannot be sustained.

Co<sub>2</sub> Systems - Provide a heavy blanket of gas that reduces the oxygen level to a point where combustion cannot occur.

The system is designed as per NFPA standard.

## CERTIFICATION

Certifications available Vds/FM/UL (as per Client Requirement)

# SUPPRESSION SYSTEM

Fire Alarm

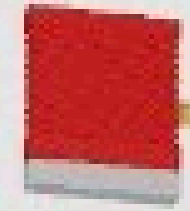

Manual Valve



# TUBE BASED SUPPRESSION SYSTEM



# Portable Fire Suppression System by ABR



The Portable Fire Suppression System by ABR – Abrol Enterprises is designed to provide smart and automatic fire protection for electrical panels and enclosed systems. It ensures advanced safety by minimizing fire risks in critical environments.

This system helps in detecting fire hazards at a very early stage, allowing quick action before the situation becomes dangerous. It plays a vital role in preventing major damage and protecting valuable equipment.

The system activates instantly when abnormal heat or fire is detected. Its fast response ensures that fire is controlled before it spreads further.

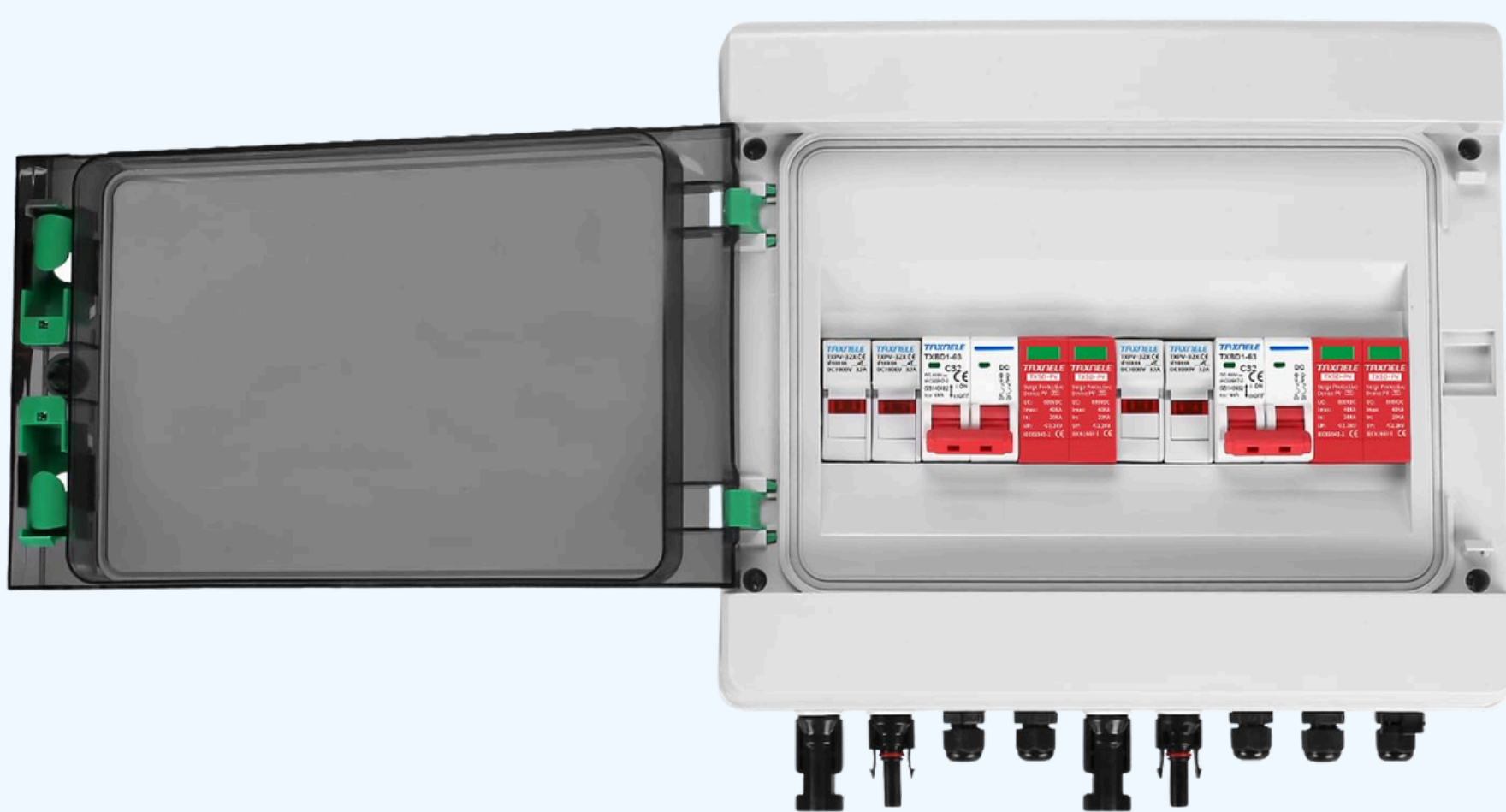

It releases a specialized non-conductive extinguishing agent that effectively suppresses fire without damaging sensitive electrical components. This makes it highly safe and reliable for electrical applications.

The system is ideal for electrical control panels, server racks, UPS cabinets, battery rooms, and industrial enclosures. It is designed to deliver dependable performance across various applications.

With features like automatic detection, fast activation, compact design, and reduced downtime, it offers complete protection. Protect your electrical systems before fire risks turn into major disasters.



# SUPPRESSION SYSTEM



## KITCHEN HOOD- TUBE BASED SUPPRESSION SYSTEM

Kitchens tend to use large quantities of hot fat and oil for the preparation of food. These fats and oils pose a particularly high fire risk. Most fires in kitchens start in deep fryers, frying pans and grilling plates, Burners with defective overheating protection. Fat self-ignites at a temperature of 350°C. which is easily reached, and fat fires tend to spread very quickly



Electrical Panels

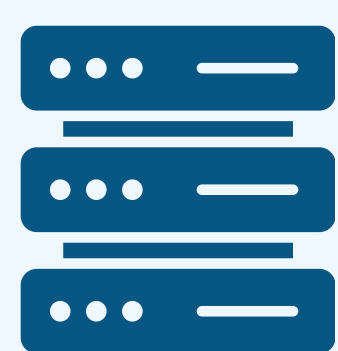

Server Rocks

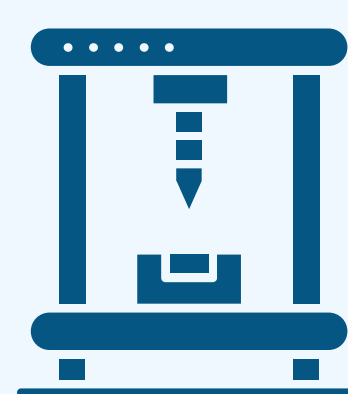

CNC Machine

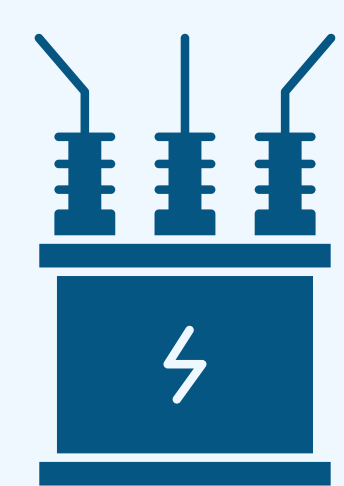

Dry Transformer

# MODULAR AUTOMATIC ABC TYPE FIRE EXTINGUISHERS



SIZES	ITEM CODE	PROPELLENT	AREA PROTECTION	VOLUME PROTECTION	HANGING VERTICALLY ABOVE RISK	OPERATION TIME IN SECONDS
2Kgs	FG000059	Nitrogen	1 to 1.5 m <sup>2</sup>	3m <sup>3</sup>	1.5	6-8
5Kgs	FG000056	Nitrogen	2 to 2.5m <sup>2</sup>	7m <sup>3</sup>	1.5m to 2m	8-10
10Kgs	FG000060	Nitrogen	4 to 5m <sup>2</sup>	12m <sup>3</sup>	1.75m to 2.25m	10-15
15Kgs	FG000061	Nitrogen	5 to 6m <sup>2</sup>	17m <sup>3</sup>	2m to 3m	15-20



## ADVANTAGES

- Can be installed on ceilings without major structural changes
- Unobstructive design – no floor space required
- Suitable for sites where other systems are impractical
- Cost-effective with flexible installation
- No extra space needed for storage containers
- Provides 24x7 automatic protection



## COMPONENTS

- Rated capacity extinguisher with solenoid valve
- Smoke & heat detectors
- Master control panel
- Manual release / abort switch
- Hooter with strobe light
- Relay module



## PERFORMANCE DATA

	A	B	C	D	E	F	G	H
Content (Agent)	Clean agent (HFC 236fa / FE 36 / HFC 227ea / FM 200)				MAP-50% / MAP-90% / MAP-90% UL Listed Powder			
Capacity	2 kg	5 kg	10 kg	15 kg	2 kg	5 kg	10 kg	15 kg
Design	Ceiling Mounted							
Dimensional Height (Approx)	380 mm	375 mm	405 mm	425 mm	380 mm	375 mm	405 mm	425 mm
Diameter (Approx)	150 +- 10 mm	230 +- 10 mm	300 +- 10 mm	400 +- 10 mm	150 +- 10 mm	230 +- 10 mm	300 +- 10 mm	400 +- 10 mm
Average Discharge time	4-5 Sec	6-8 Sec	10-15 Sec	15-20 Sec	4-5 Sec	6-8 Sec	10-15 Sec	15-20 Sec
Floor to nozzle Height	1.5 Mtr	2.0 Mtr	2.0 Mtr	2.5 Mtr	1.5 Mtr	2.0 Mtr	2.0 Mtr	2.5 Mtr
Average % Discharge	99%	99%	99%	99%	99%	99%	99%	99%
Operating Temperature	-30 °C to +60 °C							
Service / Test Pressure	15 / 35 bar							
Expelling Agent	Nitrogen (UHP grade)							
Empty / Full. [Weight (Approx.)]	1.56 / 3.56 kg	2.64 / 7.64 kg	4.11 / 14.11 kg	6.4 / 21.4 kg	1.56 / 3.56 kg	2.64 / 7.64 kg	4.11 / 14.11 kg	6.4 / 21.4 kg
Mounting Bracket	Ceiling mounting stand							



The Tube type extinguishing system has been specifically designed for use in catering/commercial kitchens. The fire detection elements respond the moment the first small flame occurs, and the fire is promptly extinguished before serious damage can occur. This system works in two ways, it is sprayed through fine nozzles onto the equipment forming a blocking layer over the fat or oil so that the fire is starved of oxygen. Simultaneously, the fat is cooled down by the water contained in the agent, so preventing self-ignition. Thus this system as effective and reliable as Conventional extinguishers. Preventing renewed self-ignition

## FEATURES

- Flexible protection
- Safety
- The pneumatic triggering
- Minimizes service stoppage during repairs
- Help prevent personnel injury



LPS 1223:Issue 2.3  
Cert.No. 724b



## SPECIFICATION

### LINE DIAGRAM

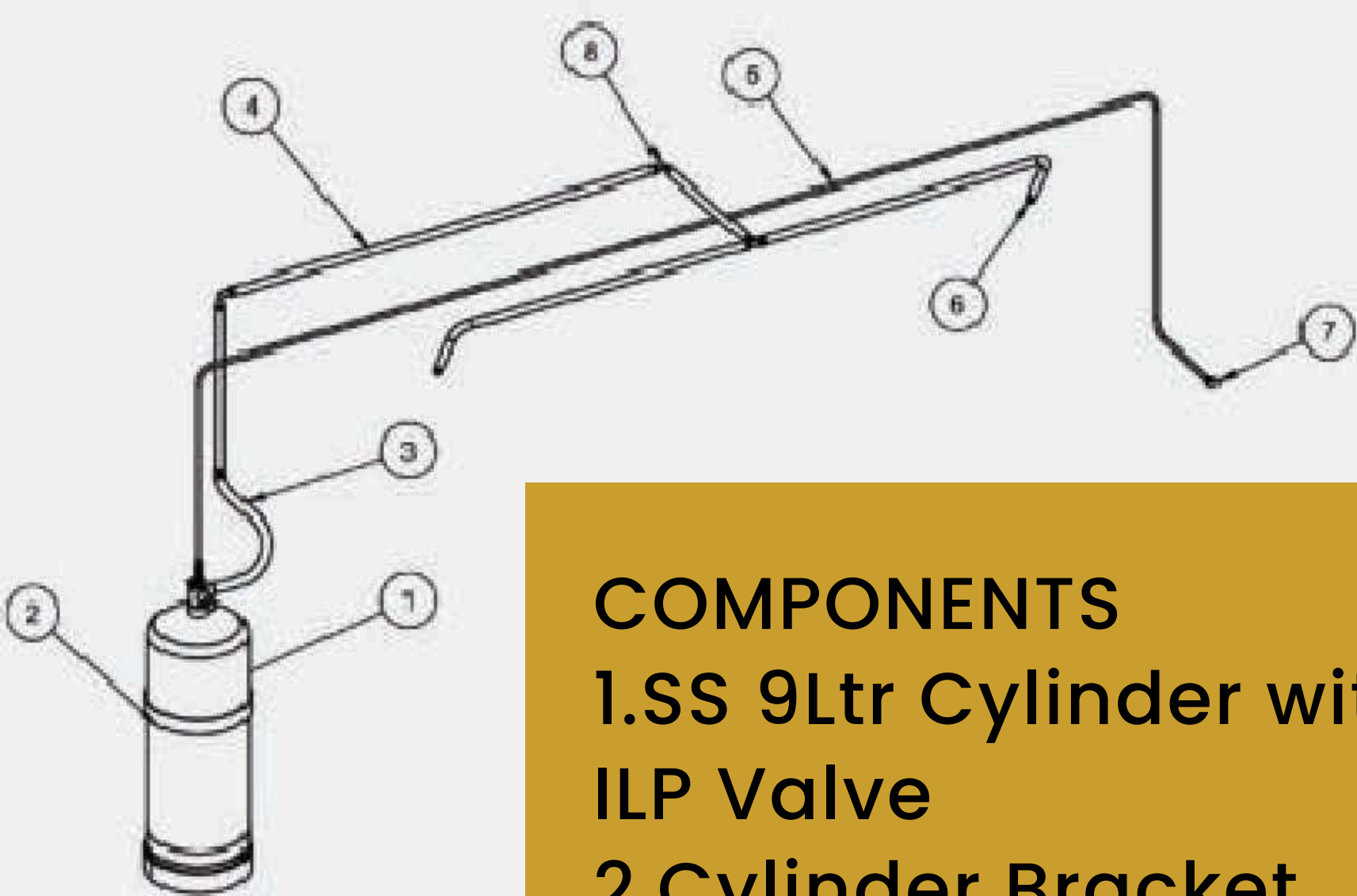

#### COMPONENTS

- 1.SS 9Ltr Cylinder with ILP Valve
- 2.Cylinder Bracket
- 3.Discharge Hose
- 4.5S Discharge Tube
- 5.Heat Sensing Tube
6. Discharge Nozzle
- 7.Manual Release

Extinguishing Agent	Class F
Propellant	Nitrogen
Volume of Extinguishing Agent	9 Ltr
Tube Pressure	16 Bar
Burst Temperature	175°C
Cylinder Pressure	16 Bar
Working Temperature	-20° C to +50°C
Cylinder Volume	12 Ltr
Weight	13 KG

# FIRE ALARM SYSTEM

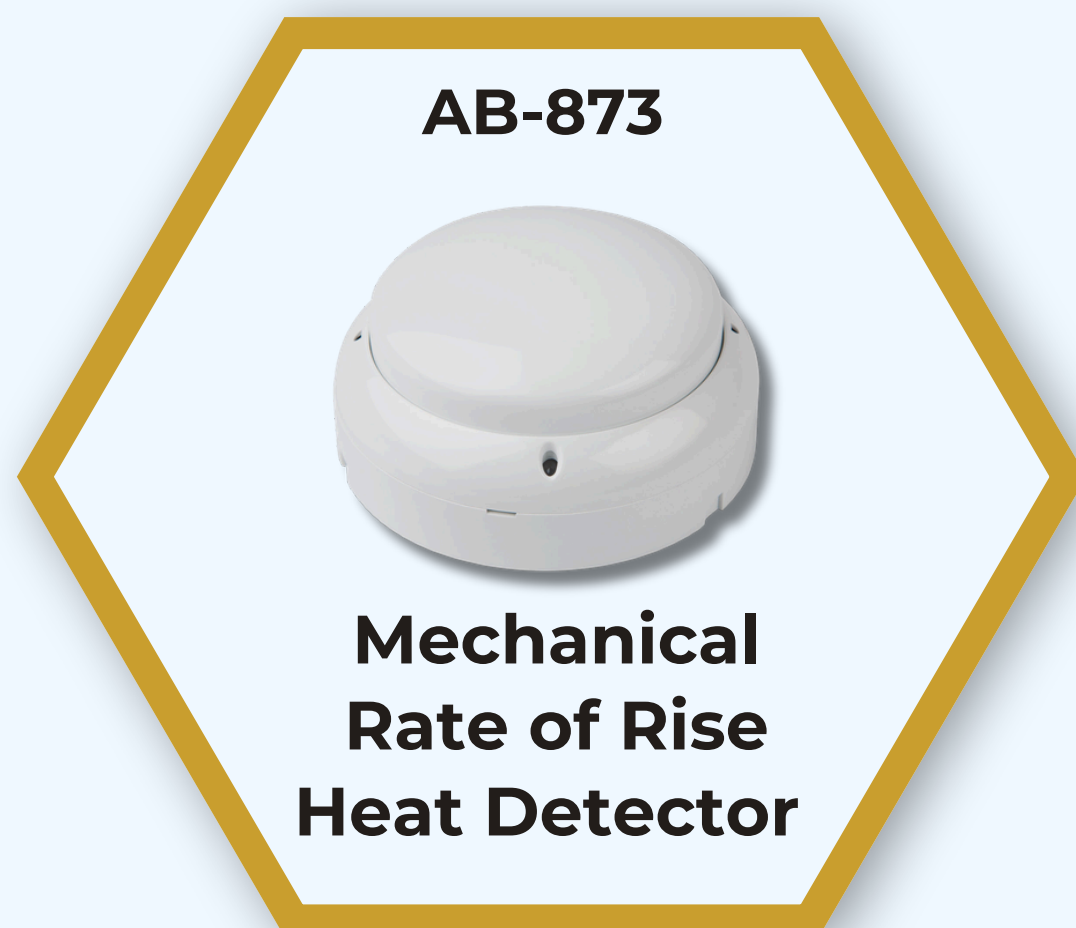
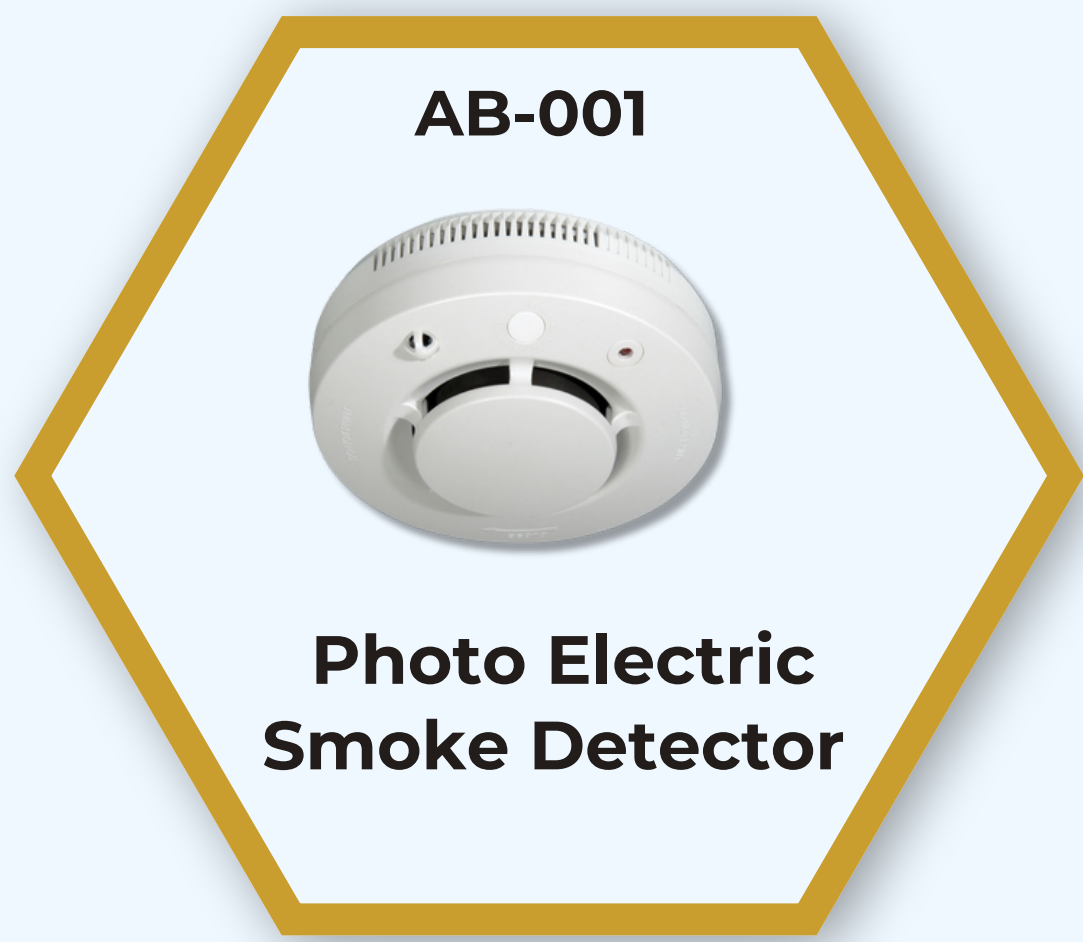

## Addressable Fire Alarm Panel

An Addressable Fire Alarm Panel is an advanced system that individually monitors and controls fire detection devices, providing precise location details of alarms or faults. It enhances response time, reduces false alarms, and allows flexible programming, making it ideal for large buildings, commercial spaces, and complex fire safety systems.

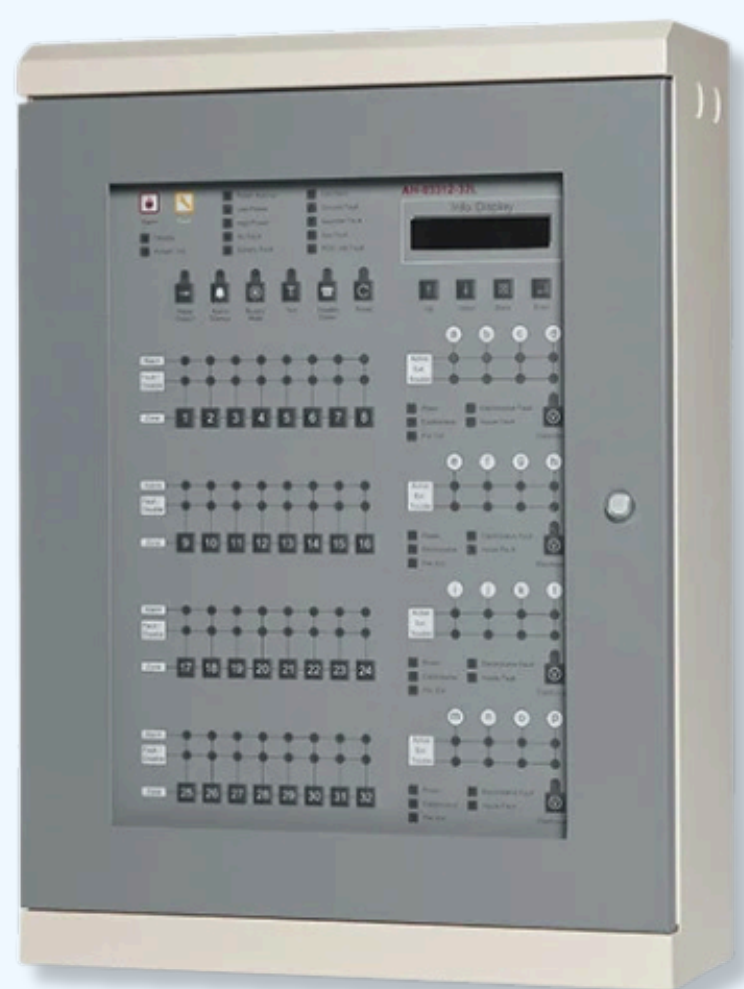

## Conventional Fire Alarm Control Panel

A Conventional Fire Alarm Control Panel divides a building into detection zones, each with multiple devices. When activated, it indicates the zone but not the exact device. It is cost-effective, simple to install, and ideal for small to medium-sized buildings where pinpoint accuracy is less critical but reliable fire detection is needed.

### MODULE



Input Module / Monitor Module  
Output Module/ Control Module  
Single Unit Input/Output Module  
Mini Zone Input/Output Modules  
Relay Modules, Loop Isolation  
Module

### BASES

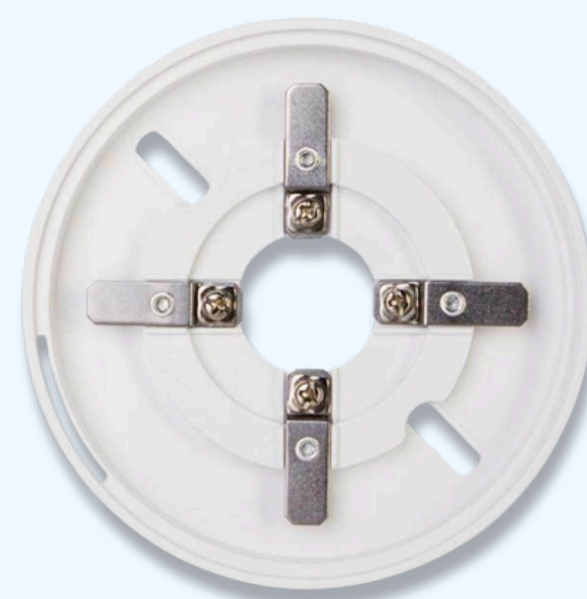

Detector Base  
Sounder/Beacon Bote Wall  
Mount Base Ceiling Mount  
Base Outdoor Mount Base  
Horn Strobe Mount Base



# FIRE EXTINGUISHER



Fire extinguishers are essential safety devices designed to control and extinguish small fires in emergency situations. They are easy to use and suitable for different types of fires, including Class A, B, and C. Equipped with effective extinguishing agents, they help prevent fire from spreading and minimize damage to life and property. Widely used in homes, offices, industries, and public places, fire extinguishers play a crucial role in ensuring quick response and fire safety compliance.



Fire  
Protection



Multi-Class  
Safety



Easy to  
Use



Wide  
Applications

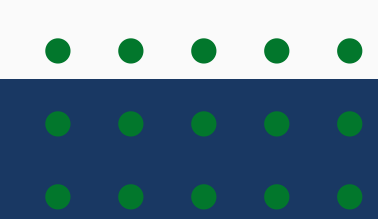

# ABC DRY CHEMICAL POWER

## FIRE EXTINGUISHER

Suitable for Class A,B & C fires that is involving Wood, Paper, Paints, Solvents, Liquid Petrol, Cloth, Flammable Gas, Electric Stated Fire. Easily operated by one person.



### TECHNICAL SPECIFICATIONS

Capacity	ABC POWDER 1 KG.	ABC POWDER 2 KG.	ABC POWDER 4KG.
BIS Specification	IS 15683:2018	IS 15683:2018	IS 15683:2018
Type of Fire	ABC	ABC	ABC
Extinguisher Type	Stored Pressure	Stored Pressure	Stored Pressure
Extinguishing Media	Dry Powder (MAP) with N2 Gas	Dry Powder (MAP) with N2 Gas	Dry Powder (MAP) with N2 Gas
Min Jet Length (mtr)	2	2	4
Test Pressure (kgf/cm <sup>2</sup> )	35	35	35
Operation Position	Upright	Upright	Upright
Operating Valve	Squeeze Grip Type with Nozzle	Squeeze Grip Type with Nozzle	Squeeze Grip Type with Discharge Pipe & Nozzle
Operating Temperature	(-) 30° to (+) 60°C	(-) 30° to (+) 60°C	(-) 30° to (+) 60°C
Fire Rating	1A, 21B	1A, 34B	2A, 55B

Capacity	ABC POWDER 6 KG.	ABC POWDER 9 KG.
BIS Specification	IS 15683:2018	IS 15683:2018
Type of Fire	ABC	ABC
Extinguisher Type	Stored Pressure	Stored Pressure
Extinguishing Media	Dry Powder (MAP) with N2 Gas	Dry Powder (MAP) with N2 Gas
Min Jet Length (mtr)	6	6
Test Pressure (kgf/cm <sup>2</sup> )	35	35
Operation Position	Upright	Upright
Operating Valve	Squeeze Grip Type with Discharge Pipe & Nozzle	Squeeze Grip Type with Discharge Pipe & Nozzle
Operating Temperature	(-) 30° to (+) 60°C	(-) 30° to (+) 60°C
Fire Rating	3A, 89B	4A, 144B



Wood, Paper, Fabric etc.



Oil, Kerosene, Petrol, etc.



Flammable Gases

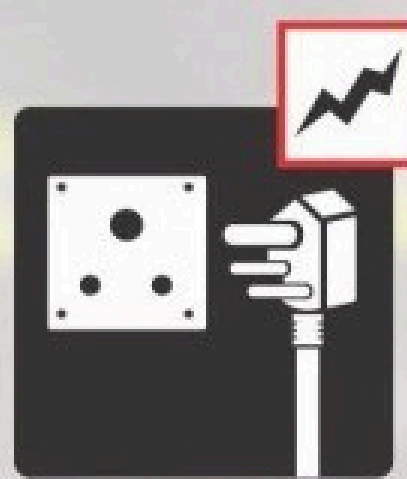

Electrical Started



# CARBON DI-OXIDE

## TYPE FIRE EXTINGUISHER

Suitable for Class B & C fires that is involving material like Fabric, Oil, Gases, Live Electric & Delicate Machineries.

### TECHNICAL SPECIFICATIONS

Capacity	Co <sub>2</sub> 2 KG.	Co <sub>2</sub> 3 KG.	Co <sub>2</sub> 4.5 KG.
BIS Specification	IS 15683:2018	AS PER IS 15683:2018	IS 15683:2018
Type of Fire	BC	BC	BC
Extinguisher Type	Stored Pressure	Stored Pressure	Stored Pressure
Extinguishing Media	CARBON DI-OXIDE	CARBON DI-OXIDE	CARBON DI-OXIDE
Min Jet Length (mtr)	2	2	3
Test Pressure (kgf/cm <sup>2</sup> )	250	250	250
Operation Position	Upright	Upright	Upright
Operating Valve	Squeeze Grip /Wheel Type	Squeeze Grip /Wheel Type	Wheel Type
Operating Temperature	(-) 30° to (+) 60°C	(-) 30° to (+) 60°C	(-) 30° to (+) 60°C
Fire Rating	21B	21B	55B



Oil, Kerosene, Petrol, etc.



Flammable Gases

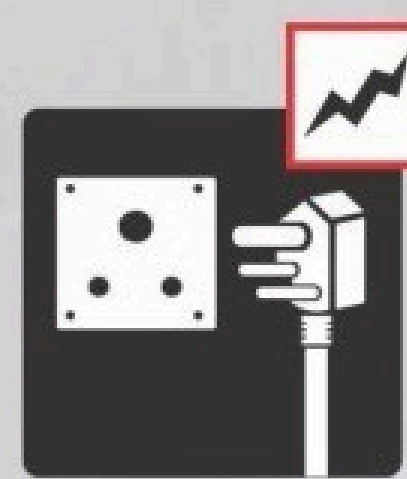

Electrical Started



# BC DRY CHEMICAL POWER

## FIRE EXTINGUISHER

Suitable for Class B & C fires that is involving Paints, Solvents, Liquid Petrol, Cloth, Flammable Gas, Electric Stated Fire. Easily operated by one person.



### TECHNICAL SPECIFICATIONS

Capacity	BC POWDER 4KG.	BC POWDER 6 KG.	BC POWDER 9 KG.
BIS Specification	IS 15683:2018	IS 15683:2018	IS 15683:2018
Type of Fire	BC	BC	BC
Extinguisher Type	Stored Pressure	Stored Pressure	Stored Pressure
Extinguishing Media	BC Dry Powder with N2 Gas	BC Dry Powder with N2 Gas	BC Dry Powder with N2 Gas
Min Jet Length (mtr)	4	6	6
Test Pressure (kgf/cm <sup>2</sup> )	35	35	35
Operation Position	Upright	Upright	Upright
Operating Valve	Squeeze Grip Type with Discharge Pipe & Nozzle	Squeeze Grip Type with Discharge Pipe & Nozzle	Squeeze Grip Type with Discharge Pipe & Nozzle
Operating Temperature	(-) 30° to (+) 60°C	(-) 30° to (+) 60°C	(-) 30° to (+) 60°C
Fire Rating	55B	89B	144B



Oil, Kerosene, Petrol, etc.



Flammable Gases

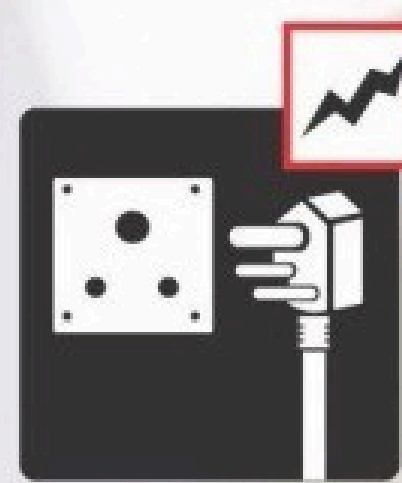

Electrical Started



# FOAM TYPE FIRE EXTINGUISHER

Suitable for Class A & B fires that is involving Carbonaceous Materials, Flammable liquids, Petroleum Products or where the blanketing effect is essential.

### TECHNICAL SPECIFICATIONS

Capacity	Foam Type 9 Liters
BIS Specification	IS 15683:2018
Type of Fire	A & B
Extinguisher Type	Stored Pressure/Gas Cartridge
Extinguishing Media	Water & AFFF IS:4989
Min. Effective Discharge (%)	95
Min Jet Length (mtr)	6
Test Pressure (kgf/cm <sup>2</sup> )	35
Operation Position	Upright
Operating Temperature	(+) 5° to (+) 60°C
Fire Rating	3A 89B

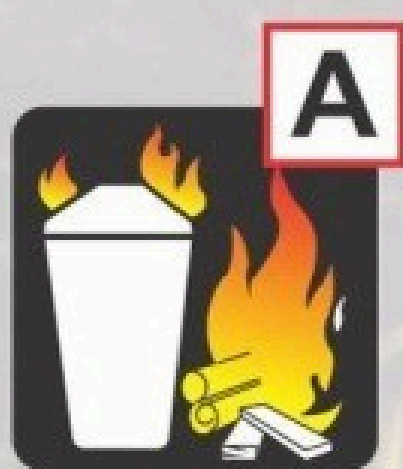

Wood, Paper, Fabric etc.



Oil, Kerosene, Petrol, etc.



**Caution : Do not use on Electrical Fire**

# WATER TYPE

## FIRE EXTINGUISHER

Suitable for Class A fire that is involving Solid Organic Carbonaceous Material Like Wood, Textile, Paper, Plastic and Rubber.

### TECHNICAL SPECIFICATIONS

Capacity	Water Type 9 Liters
BIS Specification	IS 15683:2018
Type of Fire	A
Extinguisher Type	Stored Pressure/Gas Cartridge
Extinguishing Media	Water
Min. Effective Discharge (%)	95
Min Jet Length (mtr)	6
Test Pressure (kgf/cm <sup>2</sup> )	35
Operation Position	Upright
Operating Temperature	(+) 5° to (+) 60°C
Fire Rating	3A



A

IS:15683

ISO  
9001

CE

Wood, Paper, Fabric etc. Caution : Do not use on Electrical Fire

# Modular Automatic Ceiling / Wall Mounted

## AUTOMATIC TYPE FIRE EXTINGUISHER

### ABC POWDER & CLEAN AGENT



Suitable for Class A, B & C fires that is involving Wood, Paper, Paints, Solvents, Liquid Petroleum Products, Cloth, Flammable Gas, Live Electric Fire.

### TECHNICAL SPECIFICATIONS

Capacity	5 KG.	10 KG.
Type of Fire	ABC	ABC
Extinguisher Type	Stored Pressure Ceiling Mounted	Stored Pressure Ceiling Mounted
Extinguishing Media	ABC POWDER/CLEAN AGENT	ABC POWDER/CLEAN AGENT
Test Pressure (kgf/cm <sup>2</sup> )	35	35
Operating Temperature	68°C	68°C



A

B

C

ISO  
9001

CE

Wood, Paper, Fabric etc.    Oil, Kerosene, Petrol, etc.    Flammable Gases    Electrical Started

# CLEAN AGENT TYPE

## FIRE EXTINGUISHER

Suitable for Class A, B & C fires that is involving Wood, Paper, Paints, Solvents, Liquid Petrol, Cloth, Flammable Gas, Live Electric Fire, Delicate Machineries and All Classes of Fire.



### TECHNICAL SPECIFICATIONS

Capacity	CLEAN AGENT 2 KG.	CLEAN AGENT 4KG.	CLEAN AGENT 6 KG.
BIS Specification	AS PER IS:15683	AS PER IS:15683	AS PER IS:15683
Type of Fire	ABC	ABC	ABC
Extinguisher Type	Stored Pressure	Stored Pressure	Stored Pressure
Extinguishing Media	Clean Agent	Clean Agent	Clean Agent
Min Jet Length (mtr)	2	4	6
Test Pressure (kgf/cm <sup>2</sup> )	35	35	35
Operation Position	Upright	Upright	Upright
Operating Valve	Squeeze Grip Type with Nozzle	Squeeze Grip Type with Discharge Pipe & Nozzle	Squeeze Grip Type with Discharge Pipe & Nozzle
Operating Temperature	-30° to 60°C	-30° to 60°C	-30° to 60°C



Wood, Paper, Fabric etc.

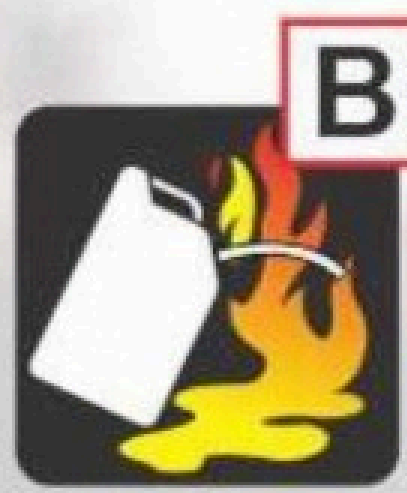

Oil, Kerosene, Petrol, etc.



Flammable Gases

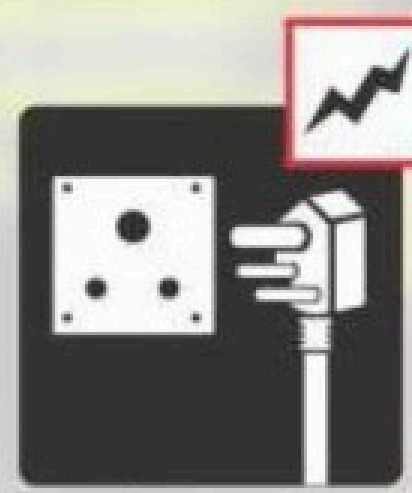

Electrical Started



# KITCHEN FIRE PROTECTION

## FIRE EXTINGUISHER

Suitable for Class A & F fires that is involving Wood, Paper, Vegetable and Animal Fat oil fires

### TECHNICAL SPECIFICATIONS

Capacity	WET CHEMICAL 2 KG.	WET CHEMICAL 4 KG.	WET CHEMICAL 6 KG.
BIS Specification	IS 15683:2018	IS 15683:2018	IS 15683:2018
Type of Fire	A F	A F	A F
Extinguisher Type	Stored Pressure	Stored Pressure	Stored Pressure
Extinguishing Media	Wet Chemical	Wet Chemical	Wet Chemical
Min Jet Length (mtr)	2	2	4
Test Pressure (kgf/cm <sup>2</sup> )	35	35	35
Operation Position	Upright	Upright	Upright
Operating Valve	Squeeze Grip Type with Nozzle	Squeeze Grip Type with Nozzle	Squeeze Grip Type with Discharge Pipe & Nozzle
Operating Temperature	+5° to +60°C	+5° to +60°C	+5° to +60°C



Wood, Paper, Fabric etc.



Cooking Media, Vegetable / Animal Oil and Fat Fires



# TROLLEY MOUNTED DRY CHEMICAL POWER

## FIRE EXTINGUISHER

Suitable for Class B & C fires that is involving Flammable Liquid Petroleum Products, Flammable Gases, Plastics & Electrical Fires.

### TECHNICAL SPECIFICATIONS

Capacity	DCP 25 Kgs (Trolley Type)	DCP 50 Kgs (Trolley Type)	DCP 75 Kgs (Trolley Type)
BIS Specification	IS: 16018	IS: 16018	IS: 16018
Type of Fire	ABC / BC	ABC / BC	ABC / BC
Extinguishing Media	Dry Chemical Powder	Dry Chemical Powder	Dry Chemical Powder
Min. Effective Discharge (%)	90	90	90
Min Jet Length (mtr)	6	8	10
Test Pressure (kgf/cm <sup>2</sup> )	35	35	35
Operation Position	Upright	Upright	Upright



Oil, Kerosene, Petrol, etc.



Flammable Gases

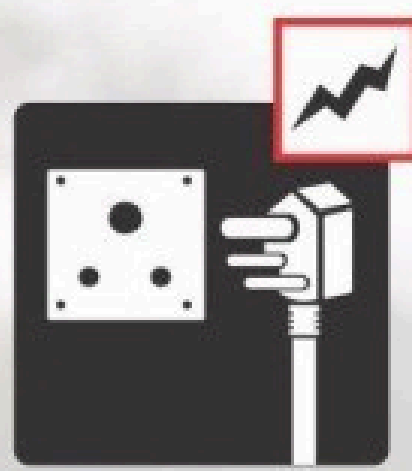

Electrical Started



# TROLLEY MOUNTED CARBON DIOXIDE

## GAS BASED FIRE EXTINGUISHER

Suitable for Class B & C fires that is involving Flammable Liquid Petroleum Products, Flammable Gases, Plastics & Electrical Fires.

### TECHNICAL SPECIFICATIONS

Capacity	CO <sub>2</sub> 6.5 KG.	CO <sub>2</sub> 9 KG.	CO <sub>2</sub> 22.5 KG.
BIS Specification	IS:16018	IS:16018	IS:16018
Type of Fire	BC	BC	BC
Extinguisher Type	Stored Pressure	Stored Pressure	Stored Pressure
Extinguishing Media	CARBON DI-OXIDE	CARBON DI-OXIDE	CARBON DI-OXIDE
Min Jet Length (mtr)	3	3	3
Test Pressure (kgf/cm <sup>2</sup> )	250	250	250
Operation Position	Upright	Upright	Upright
Operating Valve	Wheel Type	Wheel Type	Wheel Type
Operating Temperature	-30° to 55°C	-30° to 55°C	-30° to 55°C



Oil, Kerosene, Petrol, etc.



Flammable Gases

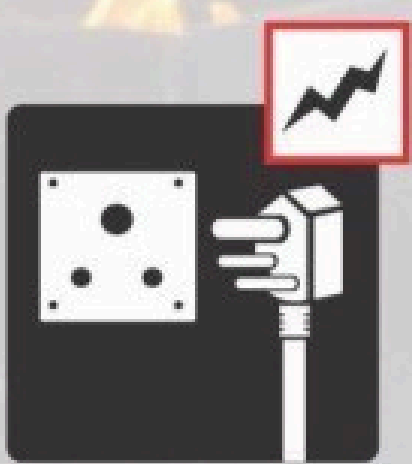

Electrical Started

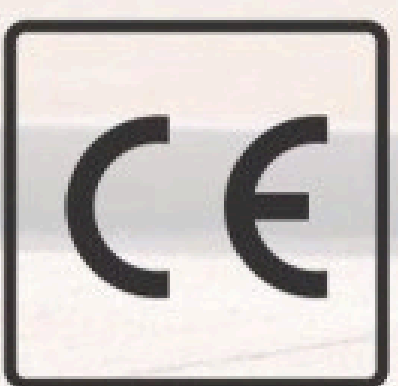

# TROLLEY MOUNTED WATER TYPE

## FIRE EXTINGUISHER

Suitable for Class A fire that is involving Solid Organic Carbonaceous Material Like Wood, Textile, Paper, Plastic and Rubber.

### TECHNICAL SPECIFICATIONS

Capacity	<b>Water Type</b> 45 Liters (Trolley Type)
BIS Specification	IS: 16018
Type of Fire	A
Extinguishing Media	Water
Min. Effective Discharge (%)	95
Min Jet Length (mtr)	6
Test Pressure (kgf/cm <sup>2</sup> )	35
Operation Position	Upright

**Caution : Do not use on Electrical Fire**



A

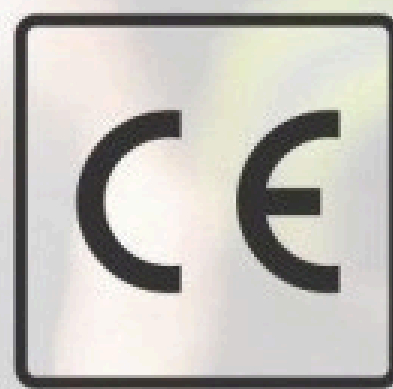

Wood, Paper,  
Fabric etc.



# TROLLEY MOUNTED MECHANICAL FOAM

## FIRE EXTINGUISHER

Suitable for Class A & B fires that is involving Carbonaceous Materials, Flammable liquids, Petroleum Products or where the blanketing effect is essential.

### TECHNICAL SPECIFICATIONS

Capacity	<b>Foam Type</b> 45 Liters (Trolley Type)
BIS Specification	IS: 16018
Type of Fire	A & B
Extinguishing Media	Water & AFFF Compound
Min. Effective Discharge (%)	95
Min Jet Length (mtr)	6
Test Pressure (kgf/cm <sup>2</sup> )	35
Operation Position	Upright

**Caution : Do not use on Electrical Fire**



A



B



Wood, Paper,  
Fabric etc.

Oil, Kerosene,  
Petrol, etc.





# FIRE RATED DOORS

Fire Rated Doors are specially designed doors made from fire-resistant materials such as steel or composite cores. These doors are tested to withstand fire for a specific duration, helping to prevent the spread of fire and smoke while ensuring safe evacuation.

Fire-rated doors come with heat-expanding seals that block smoke and flames, providing airtight protection. They are widely used in commercial buildings, factories, hospitals, schools, and residential complexes to enhance safety and meet fire compliance standards.

## Types of Fire Rated Doors

### 1. Single Leaf Fire Door

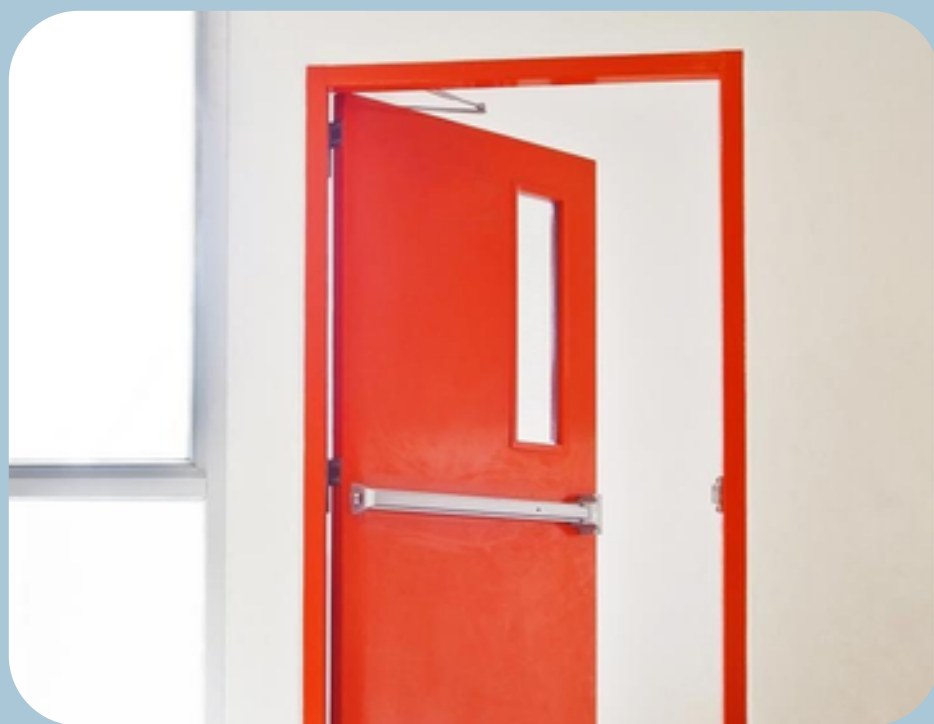

- One shutter door
- Suitable for small openings
- Common in offices and rooms

### 2. Double Leaf Fire Door



- Two shutters (double door)
- Used for wide openings like corridors and exits
- Ideal for high-traffic areas

### 3. Fire Rated Glass Door



- Includes fire-resistant glass panels
- Allows visibility with safety
- Used in modern commercial spaces

### 4. Metal Fire Rated Door



- Made of steel or metal sheets
- Strong, durable, and highly fire-resistant
- Used in industrial areas

### 5. Wooden Fire Rated Door



- Special treated wood with fire-resistant core
- Aesthetic look with safety
- Used in hotels and offices

### 6. Emergency Exit Fire Door

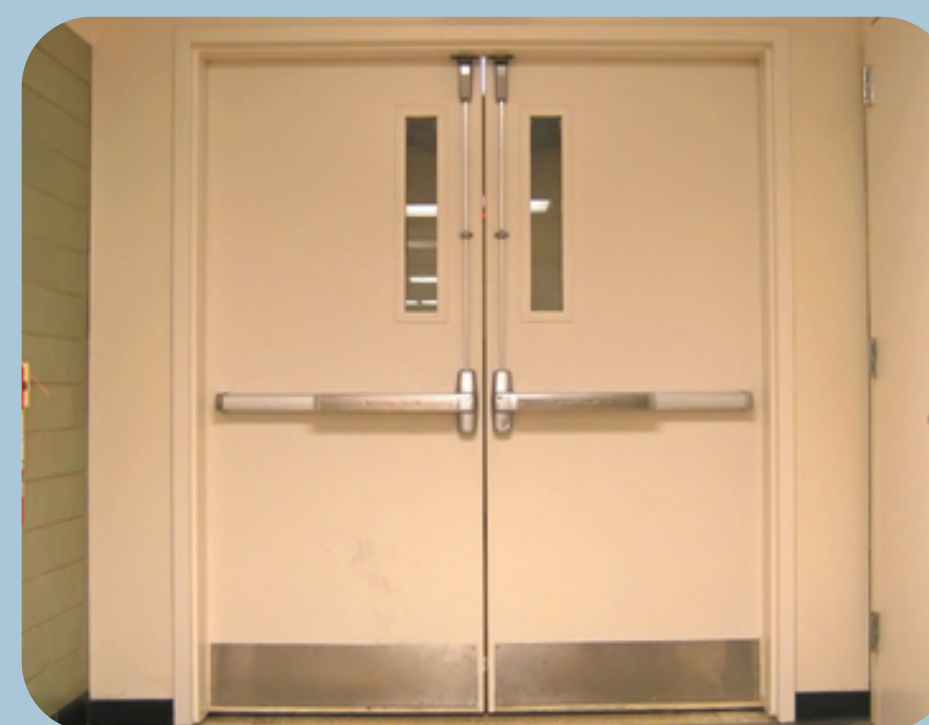

- Designed for quick evacuation
- Includes panic bars and safety hardware
- Installed in escape routes

### Fire Rating Duration

- 30 Minutes
- 60 Minutes
- 90 Minutes
- 120 Minutes

### Applications

- Commercial Buildings
- Hospitals & Schools
- Industrial Units
- Malls & Offices
- Residential Complexes

### Key Features

- Fire & smoke resistance
- Heat-expanding seals
- Durable and strong construction
- Available in various sizes & designs
- Optional glazing and insulation

# Surveillance System

## AHD/IP Network Camera



### Dome AHD/IP Camera

A Dome AHD/IP Camera is a high-definition surveillance camera designed for indoor or outdoor security. It features a dome-shaped housing for discreet monitoring and protection against vandalism. AHD (Analog High Definition) models transmit HD video over coaxial cables, while IP cameras use network connections for remote access and advanced features like motion detection, night vision, and two-way audio.

### Varifocal IR Dome AHD/IP Camera

A Varifocal IR Dome AHD/IP Camera is a high-definition security camera with an adjustable focal length, allowing flexible zoom and focus for precise monitoring. Its infrared (IR) LEDs provide superior night vision, ensuring clear footage in low-light conditions. AHD models transmit HD video over coaxial cables, while IP versions offer network connectivity for remote access, motion detection, and smart analytics. Ideal for indoor and outdoor surveillance.



### Megapixel Mini PTZ AHD/IP Camera

A Megapixel Mini PTZ AHD/IP Camera is a compact yet powerful security camera with pan, tilt, and zoom (PTZ) capabilities for flexible monitoring. It delivers high-resolution video, ensuring clear details for surveillance. AHD models transmit HD video over coaxial cables, while IP versions enable remote access, motion detection, and smart analytics. Its small size makes it ideal for discreet indoor and outdoor security applications.

### IR Weatherproof AHD/IP Camera

An IR Weatherproof AHD/IP Camera is a high-definition security camera designed for outdoor surveillance in harsh weather conditions. Its infrared (IR) LEDs ensure clear night vision, while the weatherproof housing protects against rain, dust, and extreme temperatures. AHD models transmit HD video over coaxial cables, while IP versions offer network connectivity for remote access, motion detection, and smart analytics. Ideal for reliable 24/7 security.



# Surveillance System

## HD DVR/NVR

### AHD DVR Digital Video Recorder

- Support AHD real-time encoding;
- Support VGA, HDMI HD output;
- Support XM Cloud technology
- Support various mobile monitoring: (IOS, Android)
- Support multiple web browsers (IE, Chrome)
- Video input: 4CH AHD/8CH BNC/16CH BNC;
- H.264 High Profile compression algorithm
- 1080P 25/30fps, 1080P 12fps or 720P 25/30fps Video Recorder
- Up to 500meters transmission distance
- Support 1 SATA HDD, Up to 4TB
- Support Audio Signal 10 Smart Video Analysis;
- Support Remote Monitoring
- Support manual, time based, alarm and motion based recording:
- Can trigger snapshot on alarm triggering
- Fixed DDNS;
- Support CMS
- Support PTZ Control, key button, remote Controller, Mouse Control



ADVR-3000



ANVR-6800

### NVR Network Video Recorder

An NVR (Network Video Recorder) is a digital surveillance system that records and manages video footage from IP cameras over a network. Unlike DVRs, which process video at the recorder, NVRs receive and store digital video directly from cameras, ensuring high-resolution recording and remote access. They support multiple channels, motion detection, and smart analytics, enhancing security monitoring. With features like cloud storage, HDMI output, and RAID backup, NVRs provide scalable and efficient video management for homes, businesses, and large-scale surveillance systems. Compatible with PoE (Power over Ethernet) for simplified installation, they ensure seamless integration with modern security setups.

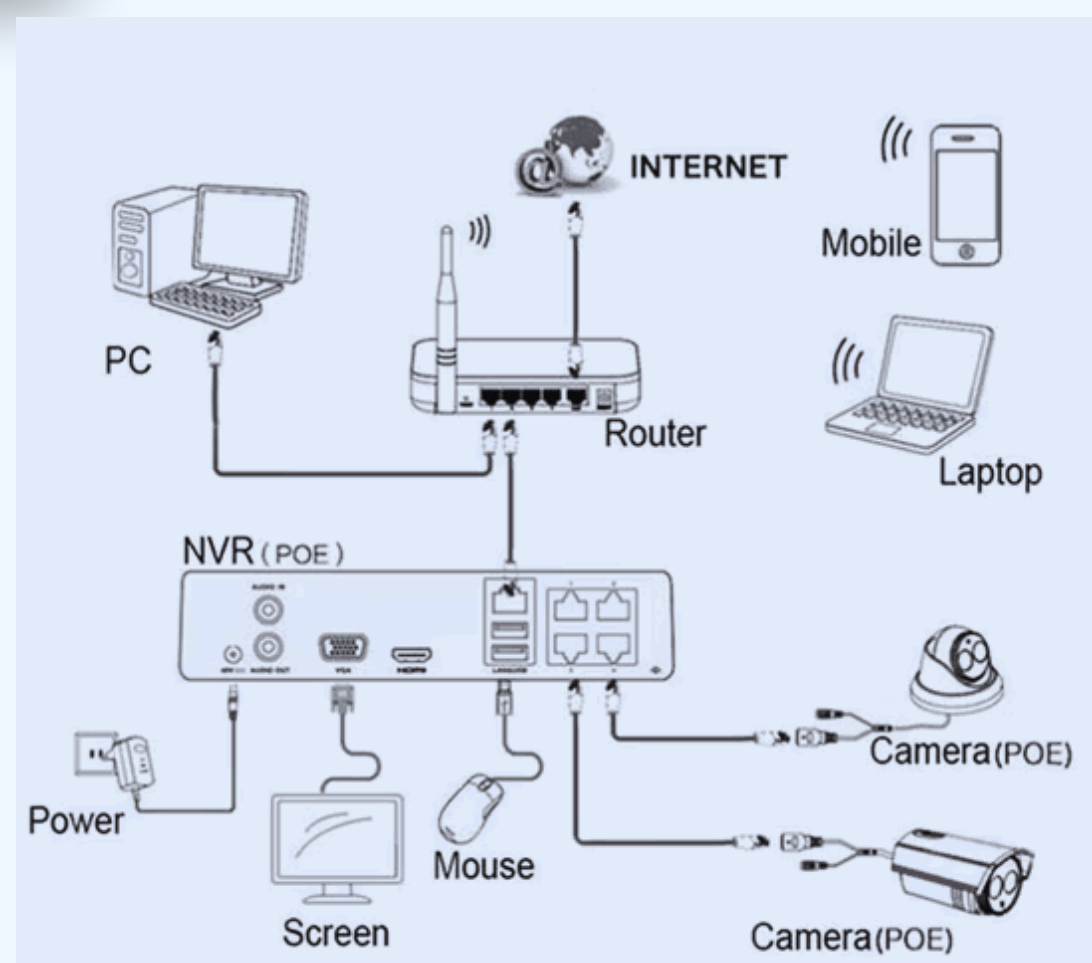

# Smart Lighting System

## TYPE OF SWITCHES



RETROFIT

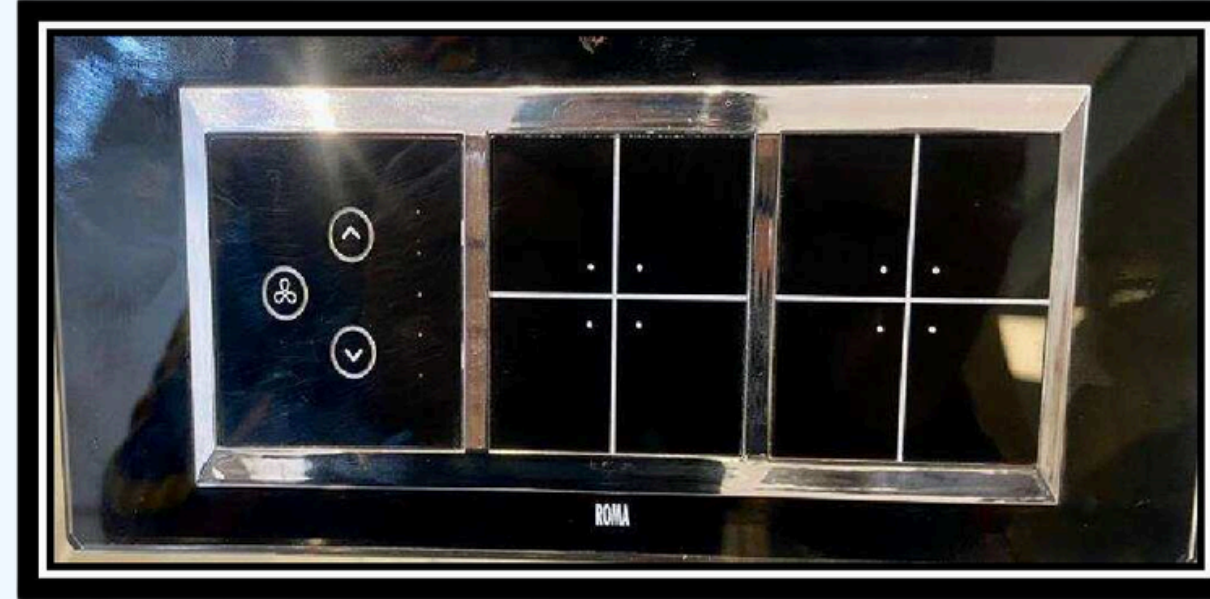

TOUCH SWITCH



TOUCH PLATE

## TYPE OF TOUCH PLATES

Touch plates are customizable and made to order, ensuring a perfect fit for specific needs with tailored designs, materials, and functionalities.

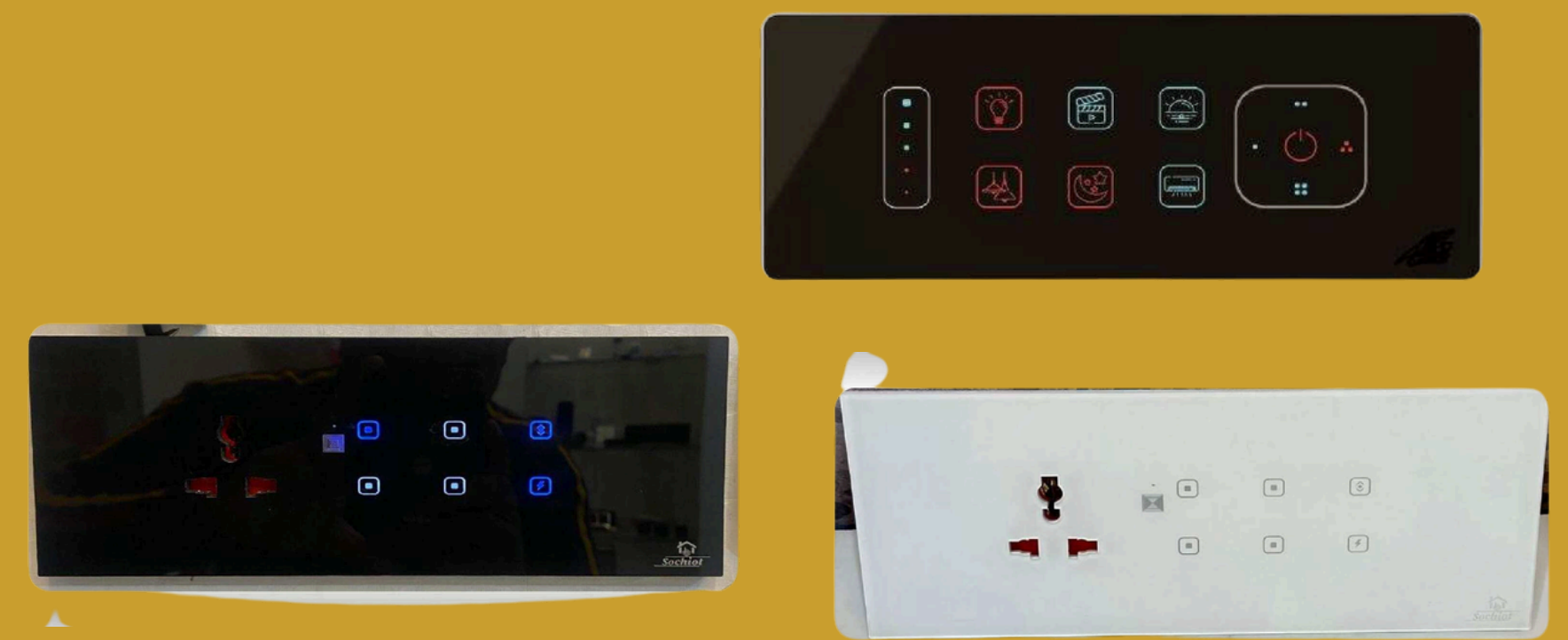

## TYPE OF MOTION SENSOR

### Motion Sensor are of Two Type

- PIR Motion Sensor
- Radar Motion sensor

### Motion Sensor are used in following area

- Corridors
- Balconies
- Staircase
- Washroom
- Parking Lot

Motion Sensor sense the motion of human body with different technologies as mentioned above. In case anyone is not in room /space it automatically turn off the Lights and in case of any movement it Switch on the light. This Saves Lot of Electricity Bills



PIR MOTION SENSOR



RADAR SENSOR



INVISIBLE RADAR SENSOR

# Home Automation System

## GSM Based Wireless Security System



A GSM-based wireless security system is an advanced security solution that uses Global System for Mobile Communications (GSM) technology to monitor and protect homes, offices, or other premises. It integrates sensors (motion, door, gas, fire, etc.) with a microcontroller, which processes signals and triggers alerts. When unauthorized access or hazards are detected, the system sends SMS alerts or calls to predefined numbers via a GSM module. This system offers real-time, remote monitoring, is cost-effective, scalable, and reliable, making it ideal for security automation.

## GSM Based Wireless touch Keypad System

The GSM-based wireless touch keypad system offers secure and convenient access control with real-time alerts via mobile networks. Featuring a sleek touch interface, it enables effortless entry while ensuring enhanced security. With remote access, motion detection, and instant notifications, it provides seamless protection for homes and businesses. Its wireless design allows easy installation, and reliable GSM connectivity ensures continuous operation, even in remote locations.



# Biometric Access Control System



## DIGITAL Glass Door Lock

### Features:

- Material: zinc Alloy
- Access solution: ngerprint, RFID card, password , Mechanical Key, Mobile App
- Scramble Pin code – Anti peek card users 100, ngerprint +card +password, power supply:4.5v-6.5v (4pcs AA battery)
- Touching Screen design – fashion and durable
- Intelligent voice navigation is easy for lock setting secure latch can protect from any break in attempts.
- 5v USB Interface

## TYPE OF DOOR BELLS

Door Bells are of Two Type

1. Battery Powered 2. Supply Powered

When anyone is on the Main gate he Will press the Bell and you will get notification on the mobile.

After Pressing the Notification you can see who is on the Door and you can also talk to him and even can take photo of Him



## TYPE OF DOOR LOCKS

### We have range of Door Locks

- Wooden Door Lock
- Glass Door Lock
- EM latch Lock
- Drawer Lock

### These Locks can be opened through Following mechanism

- Finger Print
- RFID Card
- Passcode
- OTP
- SOCHIOR APP (through wifi Dongle for outside)
- Manual Keys

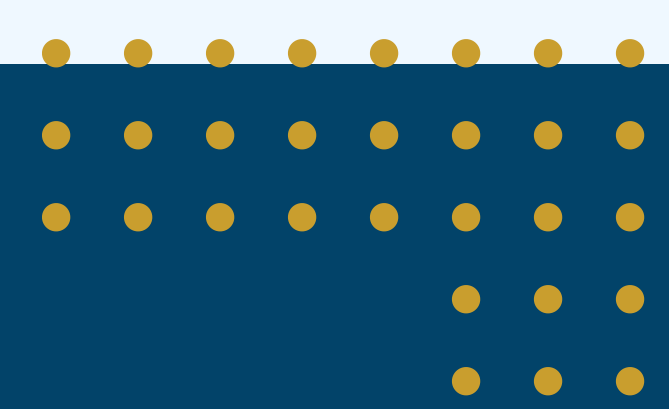

# Automatic Gates + Turnstiles

## BOOM BARRIER/GATE TOLL/PARKING GATES

Boom barriers control access in estates, parking, and tolls with a four-bar mechanism, photoelectric sensors, overheat protection, and a waterproof design.



## AUTOMATIC SLIDING GATE OPERATOR

The automatic sliding gate operator provides smooth, secure, and efficient gate movement with remote control, durable construction, and reliable performance for any entrance.



## AUTOMATIC SWING GATE SYSTEM

The automatic swing gate system ensures secure, hands-free access with smooth motion, durable construction, and smart control, ideal for residential and commercial use.



## AUTOMATIC SLIDING DOOR SYSTEM

The automatic sliding door system offers smooth, hands-free entry with motion sensors, quiet operation, and a sleek design, ideal for commercial and residential spaces.



## VERTICAL TYPES TRIPOD TURNSTILE

Vertical tripod turnstiles provide controlled access with a compact design, durable build, and smooth operation, ideal for security in various entry points.



## FLAP BARRIER TURNSTILE

Flap barrier turnstiles provide secure access control with fast, smooth operation. Equipped with sensors and a durable design, they ensure efficient, reliable entry management in various environments.

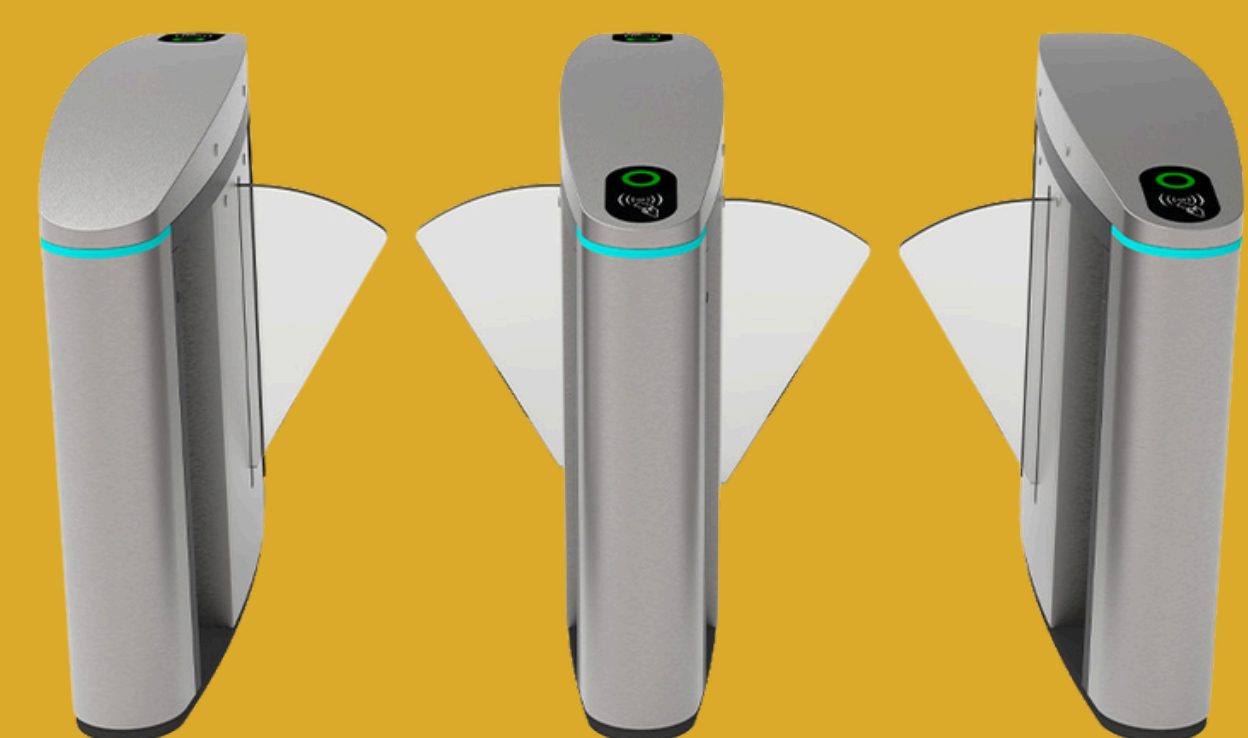

# Metal Detector

Portable DOOR FRAME  
METAL DETECTOR  
(WALK-THROUGH TYPE)

A-PDF01



Wooden DOOR FRAME  
METAL DETECTOR  
(WALK-THROUGH TYPE)

A-WDM01



6- Zone DOOR FRAME  
METAL DETECTOR  
(WALK-THROUGH TYPE)

A-LDF06



14-Zone DOOR FRAME  
METAL DETECTOR  
(WALK-THROUGH TYPE)

A-DF14



24-Zone DOOR FRAME  
METAL DETECTOR  
(WALK-THROUGH TYPE)

A-DF24

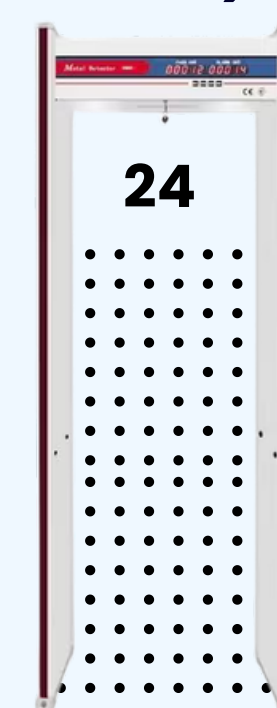

## Hand Held Metal Detector

A Hand-Held Metal Detector is a portable security device used to detect metal objects on a person or within items. It operates using electromagnetic fields to sense metallic objects, alerting the user via sound, vibration, or light indicators. Commonly used in security screenings at airports, public events, and law enforcement, it helps detect concealed weapons, knives, and other metal objects. Lightweight and battery-operated, it ensures quick, non-invasive inspections. Advanced models offer adjustable sensitivity, allowing detection of both small and large metal objects. Durable and easy to use, hand-held metal detectors enhance security and prevent unauthorized metal items from entering restricted areas.



# PA & EPABX SYSTEM

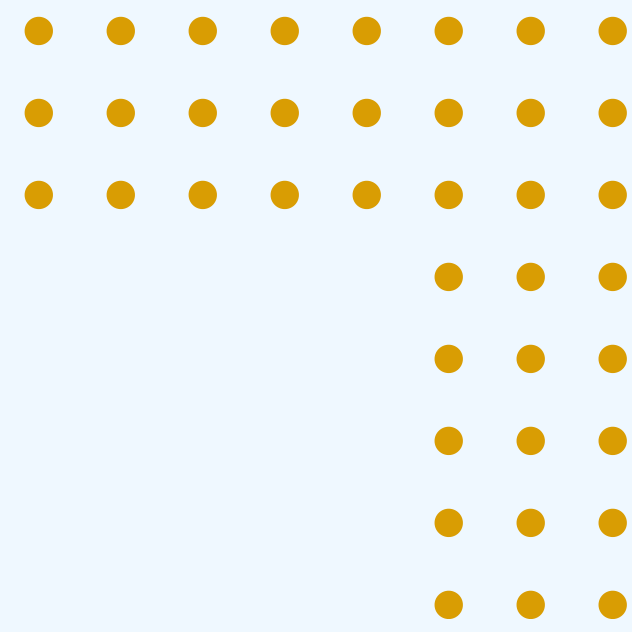
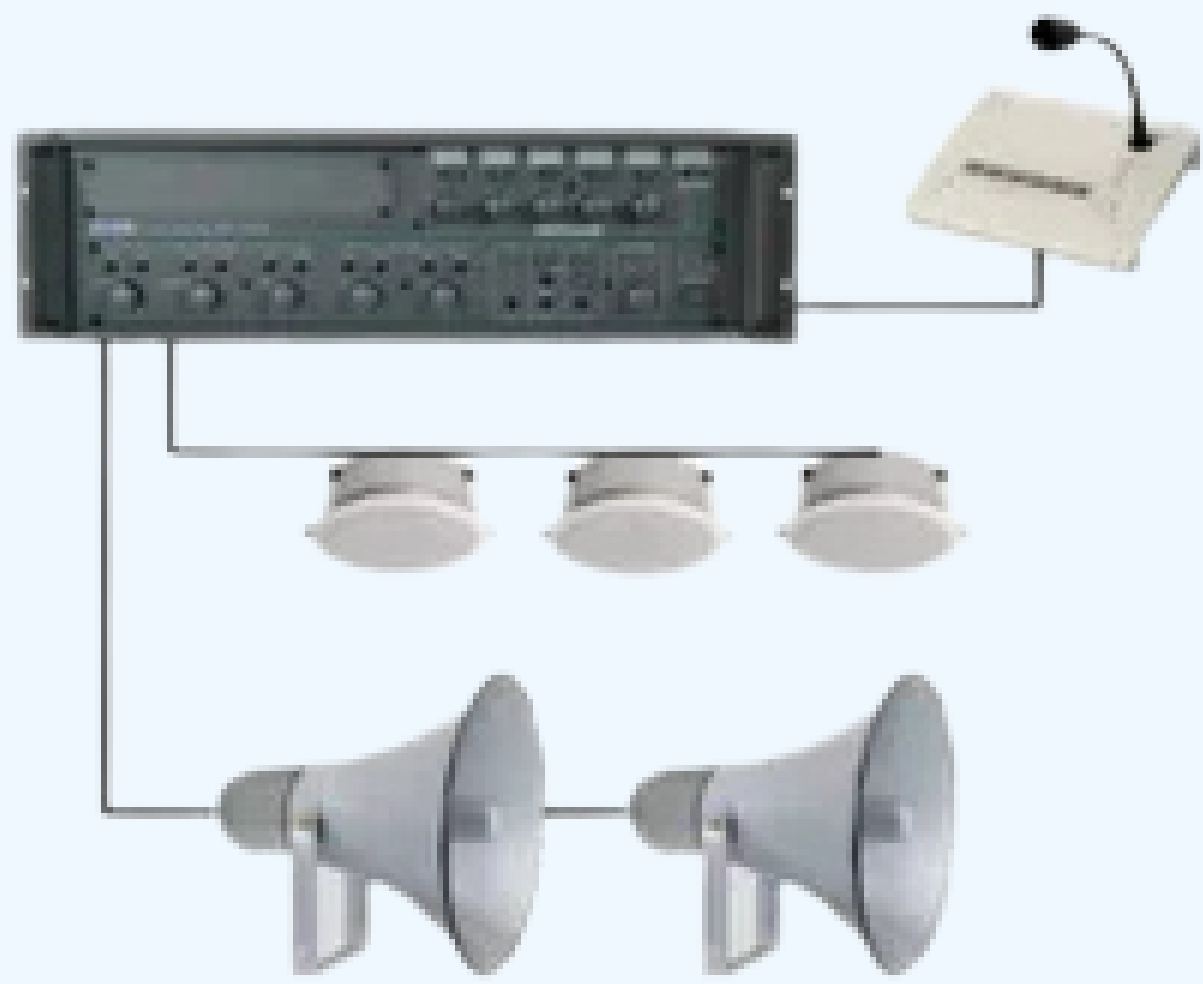

## PA SYSTEM (PUBLIC ADDRESSABLE SYSTEM)

ABROL is specializes in Audio Products & System. The Product lines include PA System, Mixer, Amplifiers, Power Amplifiers, Ceiling Speakers, Column Speaker, Wall mount Speakers, Horn Speaker, in Wall Speaker, and multi-room audio System and Microphones, Mixers, Controller, Wireless Audio system, Conference System.

Range of Products in which we are dealing,

CENTRAL PAGING AND EVACUATION SYSTEM  
WITH BACKGROUND MUSIC CONFERENCE  
SYSTEMS BUSINESS MUSIC SYSTEMS PUBLIC  
ADDRESS SYSTEMS/EQUIPMENTS PRO AUDIO  
PRODUCTS WIRELESS MICROPHONES 2 WAY  
TALK BACK SYSTEMS DJ SYSTEMS



## EPABX & INTERCOM SOLUTIONS- [EPABX] ELECTRONIC PRIVATE AUTOMATIC BRANCH EXCHANGE

A private branch exchange (PBX) is a telephone exchange that serves a particular business or office, as opposed to one that a common carrier or telephone company operates for many businesses or for the general public. PBXs are also referred to as PABX -private automatic branch exchange and EPABX.

The feature of a call transferring and forwarding is another area enabling mobility of the users. Autoconferencing and automatic redialling of numbers found engaged on the first trial are some of other advancements in the features of the EPBAX.

### System Capacity

- 64 & More Extension Ports
- 64ch & More Trunk Ports

### System Features

- Automatic ISDN Setting (BRI)
- Automatic Route Selection (ARS)
- PC Console/PC Phone
- OR Least Cost Routing (LCR)
- PC Programming
- VIP-Call
- Visual Caller ID
- Digital eXtra Device Port (XDP)
- Hands-free Operation

### DECT Features

- Automatic Handover
- Wireless XDP Parallel Mode

### ISDN Service Features

- Calling Line Identification Presentation (CLIP)
- Direct Dialling Inward (DDI)
- ISDN Call Forward (CFU/CFNR/CFB)
- Multiple Subscriber Numbers (MSN)

### Networking Features

- ARS with VoIP
- QSIG Connection
- VoIP Network (Built-in IP-GW)

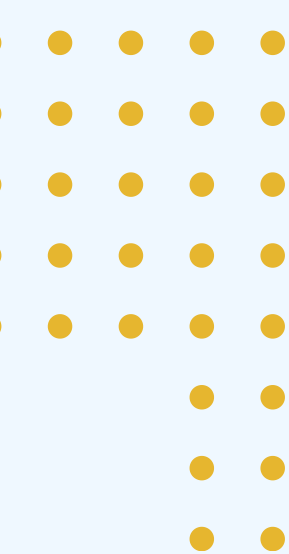

# PERSONAL PROTECTION KIT FOR DAILY INDUSTRIAL USE SET-007

This kit is equipped with all necessary protective wears that are required for ensuring the minimal safety of the personnel at work and protect them from accident & injuries.

This kit is very suitable in almost all industries including construction & civil works..



**Safety Helmet  
(1pc)**



**Reflective Vest  
(1pc)**



**Safety Goggles  
(1pc)**



**Safety Shoe  
IS15298\*PII (1pr)**



**Safety Dotted  
Gloves (1pr)**



**Ear Plug  
(1set)**



**N95 Mask  
(1pc)**



**Kit Bag  
(1pc)**

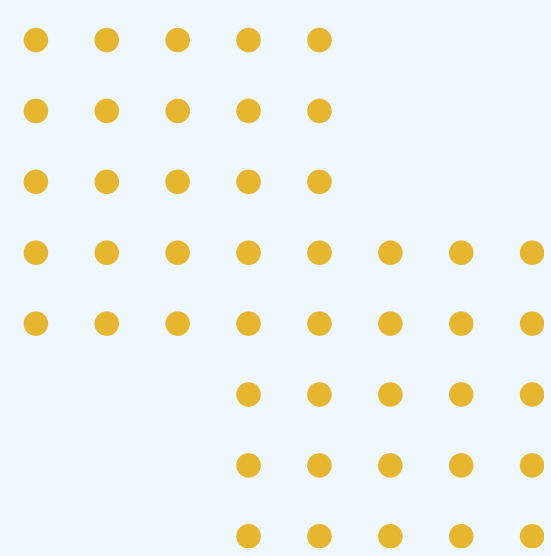

## COMPANIES THAT TRUST OUR SOLUTIONS

ABROL have very good and wide Dealer network (Distribution of material through our dealer) in all over India i.e. Punjab, Haryana, Himachal Pradesh, Uttaranchal, Rajasthan, Uttar Pradesh, Gujarat.

### Some of our clients are as follows:

Chandigarh Police	Metro Institute of Medical Science Pvt. Ltd., Noida
Government of India (Provided Surveillance to Prime Minister)	Oasis Immigration & Consultants Pvt. Ltd., Chandigarh
Shimla Police -Ridge and Mall Road, Himachal Pradesh	PostGraduateInstituteofMedicalEducationandResearch,Chandigarh(PGI)
Punjab Police (Head Quarter), Chandigarh	CLAAS India Private Ltd., Morinda (Pb.)
BSF (Western Command) Chandigarh	Delhi Public School, Chandigarh (DPS)
Punjab University, Chandigarh	CADILA Healthcare Ltd., Baddi (HP.) ZYDUS
Judicial Academy Chandigarh	United Biscuit Ltd., KalaAmb
Adiya Birla Group	IVY Hospital, Mohali
Jindal Industries	Malwa Industries Ltd., Ludhiana
Johnson and Johnson Ltd., Baddi	Indian Oil Corporation, Chandigarh
IDS Ltd., Mohali	Mahindra & Mahindra, Ltd., Haridwar
USV Pharma, Baddi	Parle Biscuit Pvt. Ltd., Neemrana
Hero Moto Corps Limited, Sidcul - Haridwar	Baba Ramdev Patangali, Haridwar
Mahle Filters Pvt. Ltd., Parwanoo (ANAND Group)	International Fresh Farm Mega Food Park Ltd., CHD - Sangrur, Channo, Fazilka Sites
GBP Group, Zirakpur, Punjab	Sushma Build tech Ltd., Zirakpur
Jones Lang LaSalle Building operations Pvt Ltd, Gurgaon	Motia Group; Royal Motia, Zirakpur
Bollywood Height, Punjab	Jal Vayu Towers, Mohali, (JVT)
Janta Land Promotors Ltd., Mohali, Pb. (JLPL)	Mankind Pharma Ltd., Sirmour, HP
Maya Garden, Zirakpur, Punjab	Tirupati Life sciences pharma Pvt. Ltd., Kala-amb, HP
EXIM Bank, Elante, Chandigarh	Punjab State E- Govenner Society
Sungro Seeds Ltd., Delhi	Trackon Couriers pvt. Ltd, Chandigarh
Satluj Spintex limited, Mansa	Nandos, Sector35, Chandigarh
Modulus Pvt. Ltd., Parwanoo.	The Majestic Hotel, Mohali
MCM DAV School, Chandigarh	Affy Pharma Pvt. Ltd., Baddi
Talwar Dairies, Chandigarh	Monad profiles, Panchkula
Poddar Tyres Ltd., Ludhiana (Bedrock)	Shehensha Restaurant, Chandigarh

Punjab Vigilance Department, Chandigarh	Vishav Manav Ruhani Kendra, Baddi
Zavor Jeweller, Sector-22, Chandigarh (ManyotherJwellersinTricity)	Competent Synergies India Pvt. Ltd., Chandigarh & Mohali
Emerging India Pvt., Ltd., Chandigarh	Raffles Millennium fashion School, Chandigarh
Shinmar Industries, Mohali	Unisex Solutions, Mohali
Competent Synergies Pvt. Ltd., CHD Mohali	Modulus Pvt. Ltd., Parwanoo.
AIRAWAT ARMY Canteen, Patiala	Sky Net Tower, Zirakpur
IDS Infotech Limited, Mohali	Mayfair Apartment, Mohali
Competent House, Chandigarh	A. R. Electrical, Haridwar(U.K.)
CII, Chandigarh	Revati Print-O-Packs Ltd., Haridwar (U.K.)
Shahid Udham Singh Collage, Tangori	Shivalik Public School, Chandigarh & Nawasheher
J.B.J. Internationals. Ltd., Baddi	SnowPack, Bhadrabad, Haridwar(U.K.)
J.B.J. Perfumers Pvt. Ltd., Baddi	HQ Lamps Ltd., Haridwar(U.K.)
Vaishnabi Cosmetics, Baddi	Goel Lighting ltd., Haridwar (U.K.)
Vishwas publication, Mohali	INDIA Meditech ltd., Haridwar (U.K.)
Mohan Fibers, Derabassi	Garg Motors, Yamunanagar
Amba Polytechnic, Derabassi	Hero Moto Corps Limited, Neemrana(Rj)
Vishwas Pharmaceuticals, Mohali	Unitech Enterprises, Mohali
Cambay-Five star Hotel Udaipur	AP Induction, Mohali
Gupta Associates, Chd.	Bhogal Industries, Mohali
Chandigarh almost all Guest houses.	Azad Printers, Chandigarh
TNG, Mohali	Prince offset Printers, Chandigarh
Samsung, Mohali	Shivalik Public School, Mohali
G.K. Traders, Mohali	Sitson India Pvt. Ltd., Pune
Geekan Designes, Baddi	Laxshmi Energy & Foods Ltd., Khamanon
Gayatari Industries, Baddi	Aakaar Designs, Chandigarh
Dee & Vee Associates, Mohali	Atma Ram Jewellers, Panchkula
Bhai Matadaas society, Panchkula	Mind Tree School, Kharar
Moti Mahal (Zaika), Chandigarh	Zee Litra School, Derabasi
Mikado Group, Panchkula	Ethos Limited, Chandigarh
Sialkot House, Ambala	Raj & Associates, Chandigarh
Raj Interiors, Chandigarh	New Panipat Handloom, Haridwar(U.K.)
R.K. Garg, Ambala	Bikanerwala, Haridwar
Godrej	Baddi, Himachal Pradesh
Immacule life science	Baddi, Himachal Pradesh
Helios Pharmaceutical	Baddi, Himachal Pradesh
And Many More.....	

## CERTIFIED UNDER BELOW ASSOCIATION



Confederation of Indian Industry



## Our Recognitions:

When seeking a product development partner for Safety & Security, it's essential to choose one recognized by industry-leading organizations. ABROL takes pride in creating innovative products that have been certified and approved by major organizations in technology and development.

## AUTHORIZED PARTNERS



## Contact Us

Phone

+91 9915222897

Website

[www.abrolventures.com](http://www.abrolventures.com)

Email

[sale@abrolventures.com](mailto:sale@abrolventures.com)

**“Smart security, seamless automation – safeguarding your world with innovation!”**